

Development of a Novel Gas Pressurized Stripping (GPS)- Based Technology for CO₂ Capture from Post-Combustion Flue Gases DE-FE0007567

**Carbon Capture Scientific, LLC.
CONSOL Energy Inc.
Nexant Inc.
Western Kentucky University
HiGee USA Inc.**

Presented by Shiaoguo (Scott) Chen

DOE Carbon Capture Technology Meeting, July 29-August 2, 2014, Pittsburgh, PA



Acknowledgements

**Funded by U.S. Department of Energy/ National Energy
Technology Laboratory under Agreement No. DE-FE0007657**

This report was prepared as an account of work sponsored by an agency of the United States Government. Neither the United States Government nor any agency thereof, nor any of their employees, makes any warranty, express or implied, or assumes any legal liability or responsibility for the accuracy, completeness, or usefulness of any information, apparatus, product, or process disclosed, or represents that its use would not infringe privately owned rights. Reference herein to any specific commercial product, process, or service by trade name, trademark, manufacturer, or otherwise does not necessarily constitute or imply its endorsement, recommendation, or favoring by the United States Government or any agency thereof. The views and opinions of authors expressed herein do not necessarily state or reflect those of the United States Government or any agency thereof.

About Carbon Capture Scientific, LLC

- ❑ Early stage company located in Pittsburgh, PA
- ❑ Two patent granted CO₂ capture technologies
- ❑ Bench-scale development funded by the Department of Energy / National Energy Technology Laboratory
- ❑ Chemical Engineers/Scientists with strong expertise in process design, simulation and optimization
- ❑ Technology development based on transition from thermodynamic analysis, to process simulation, to bench scale prototyping
- ❑ Continuing to make key hires to build in-house expertise for current and future large scale projects

Project Budget (Revised)

	Budget, \$
DOE	3,347,370
CCS	847,799*
Total	4,195,169

*including cost share from CONSOL Energy Western Kentucky University, and HiGee USA

(Cost share is ~20%)

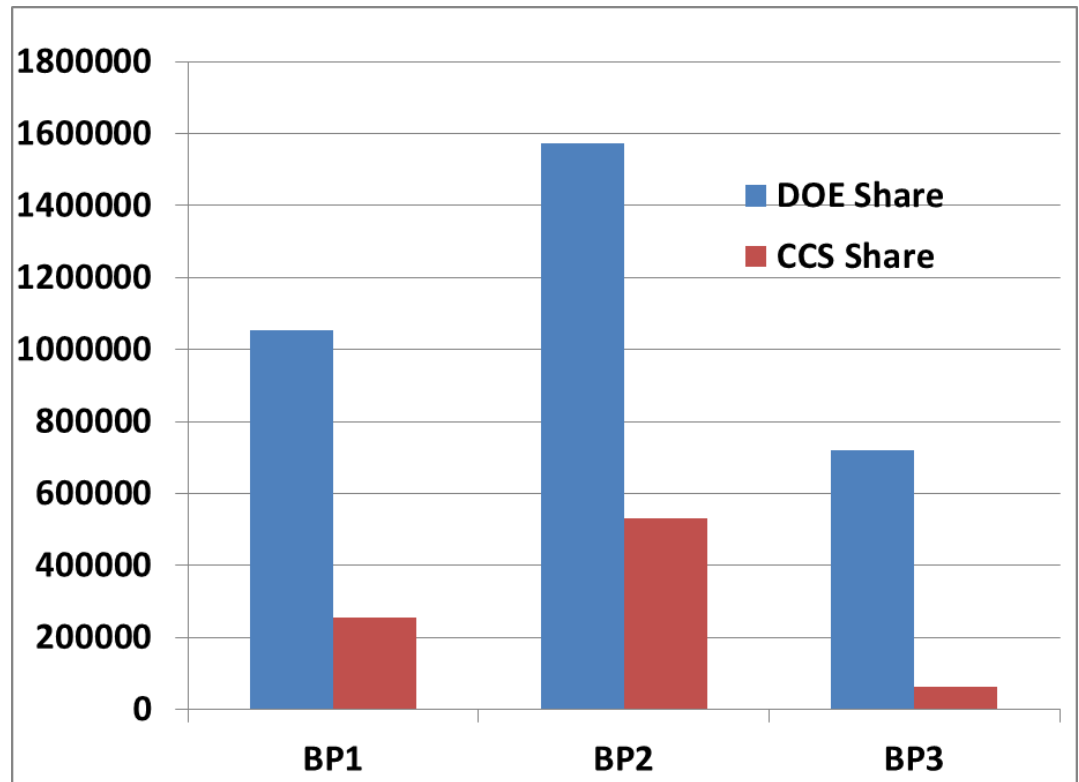

DOE funding and cost share based on Budget Period

Project Participants

Partner/ Organization	Lead Contact(s)	Key Role(s)
DOE-NETL	Andrew P. Jones, Project Manager	-Funding & Sponsorship
Carbon Capture Scientific, LLC	Shiaoguo (Scott) Chen, PI Zijiang (John) Pan, Co-PI	-Process optimization -Bench-scale experiments
CONSOL Energy Inc.	Daniel P. Connell, Co-PI Richard Winchel, Technical advisor	-Phase equilibrium experiments and related process design
Nexant Inc.	Gerald Choi, PI Robert Chu, Sr. Chemical Engineer	-Techno-economic analysis
Western Kentucky University	Prof. Wei-Ping Pan	-Consultant on corrosion testing
HiGee USA	Prof. Jiangfeng (Jeffery) Chen	-Specialty equipment (RPB) provider

Project Objectives

Overall Objective

- Develop a breakthrough Gas Pressurized Stripping (GPS) process-based technology for CO₂ capture from post-combustion flue gases

Specific Objectives

- Perform bench-scale tests of individual process units to obtain necessary process design data for the pilot scale
- Conduct computer simulations to maximize the benefit of the GPS technology for existing power plants
- Carry out experimental investigation of selected solvents to minimize the economic risk of the GPS technology.
- Perform bench-scale tests of a rotating packed bed (RPB) to evaluate performance.
- Design, build, and test a GPS skid capable of processing 500 SLPM actual coal-derived flue gas in a column-based GPS system operating at the National Carbon Capture Center (NCCC).

Revised Project Schedule: Oct.1, 2011 –June 30, 2015

Tasks	Task Duration												Task Focus	Performer				
	1-12 BP1				13-33 BP2				34-45 BP3					CCS	HiGee	CONSOL	Nexant	WKU
Task 1. Project planning & management													N/A	X				
Task 2. GPS column study and its optimization													Process	X				
Task 3. Optimization of GPS process for existing plant													Process	X				
Task 4. Simulations of Alternative Separations method for GPS stripping gas													Process	X				
Task 5. Phase equilibrium data measurement													Solvent	X			X	
Task 6. First absorption column testing													Process	X			X	
Task 7. GPS column design/fabrication and testing													Process	X			X	
Task 8. Second absorption column testing													Process	X			X	
Task 9. Stability of solvent at high loading and high T													Solvent	X				X
Task 10. Corrosion test at high loading and high T													Solvent	X				X
Task 11. RPB unit evaluation at CCS Laboratories													Equipment	X	X			
Task 12. Survey of EH&S of GPS process													Solvent	X				
Task 13. Preliminary techno-economic analysis													Economics					X
Task 14. Revision of techno-economic analysis													Economics					X
Task 15. Updated techno-economic analysis													Economics					X
Task 16. Design/fabrication of a Continuous GPS System with Conventional Columns													Process	X				
Task 17. Bench-Scale Testing of the Skid Mounted Column Based GPS System													Equipment	X				

BP1 Tasks: All Completed on Schedule

Task #	Description	Simulation / Experiment	Comments
2	GPS column study and its optimization	Simulation	Completed
5	Phase equilibrium data measurement	Experiment	Completed
6	First absorption column testing	Experiment	Completed
9	Stability of solvent at high loading and high T	Experiment	Completed
13	Preliminary techno-economic analysis	Simulation	Completed

Milestones Achieved for BP1

Task	Title/Description	Planned Completion Date	Actual Completion Date	Verification Method
2	GPS column study and optimization to achieve thermal efficiency of 60% or greater	9/30/2012	7/9/2012	Design review with NETL / Presentation of data
9	Solvent loss due to degradation of solvent is less than 3 kg/ton CO ₂	9/30/2012	7/9/2012	Design review with NETL / Presentation of data

BP2 Tasks

Task #	Description	Simulation / Experiment	Focus	Status
1	Project Management	---	Project Management	
3	Optimization of GPS process for existing plant	Simulation	Identify optimal operating conditions for GPS process	Completed
4	Simulation of alternative separation for GPS stripping gas	Simulation	Identify separation process to follow GPS process	Completed
7	GPS column design/ fabrication and testing	Experiment	Experimentally validate GPS concept	Completed
8	Second absorption column testing	Experiment	To recover stripping gas	Completed
10	Corrosion test at high loading and high temperature	Experiment	Obtain corrosion data	Completed
11*	RPB unit evaluation at CCS Laboratories	Experiment	Assess RPB potential to replace conventional column	Completed
14	Revision of techno-economic analysis	Simulation	Identify cost reduction potential	Completed
16*	GPS system design/ fabrication and installation	Experiment	Establish a skid mounted GPS system	Completed

*** Revised or new task for BP2**

Milestones Achieved for BP2

Task #	Description	Planned Completion Date	Actual Completion Date
1	Host site agreement executed	6/30/2013	6/30/2013
3	Overall energy performance column and solvent less than or equal to 0.22 kwh/kg CO ₂	9/30/2013	12/30/2012
4	Overall energy performance of system less than or equal to 0.20 kwh/kgCO ₂	9/30/2014	2/25/2013
7	GPS column efficiency experimental measured at 50% or greater	9/30/2013	2/25/2013
16	Complete design of bench-scale GPS test unit for conventional columns	4/30/2013	5/20/2013
16	Completion of the fabrication and shakedown of the skid-mounted GPS system using water and air	3/31/2014	5/23/2014
16	Complete installation of 500 SLPM column-based GPS bench unit at NCCC	5/31/2014	*8/10/2014

* Expected

Task 4: Simulation of alternative separation for GPS stripping gas

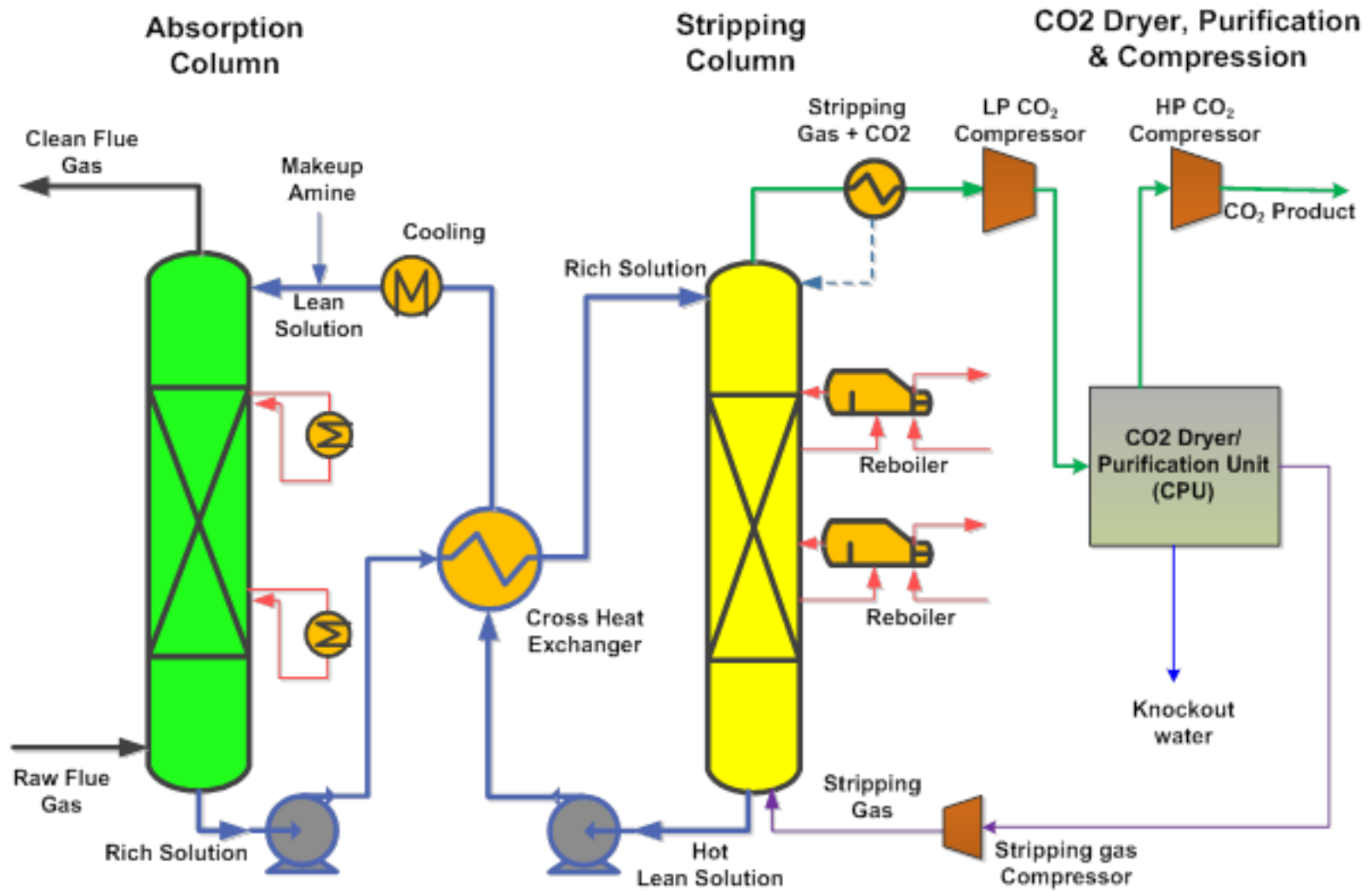

Task 4: Simulation of alternative separation for GPS stripping gas

Purpose

- To identify alternative separation process for stripping gas recovery

Accomplishment

- Identified compression/refrigeration method as a better alternative to second absorption process, overall energy performance:

Capture percentage, %		90.20
CO ₂ product purity mol.%	CO ₂	97.63
	H ₂ O	0.24
	N ₂	2.13
Heat requirement (electricity equivalent), kWh/kg CO ₂		0.11
Electricity need, kWh/kg CO ₂		0.10
Overall energy performance, kWh/kg CO ₂		0.21

Success criteria of energy performance column and solvent ≤ 0.20 kwh/kgCO₂

Task 4: Simulation of alternative separation for GPS stripping gas

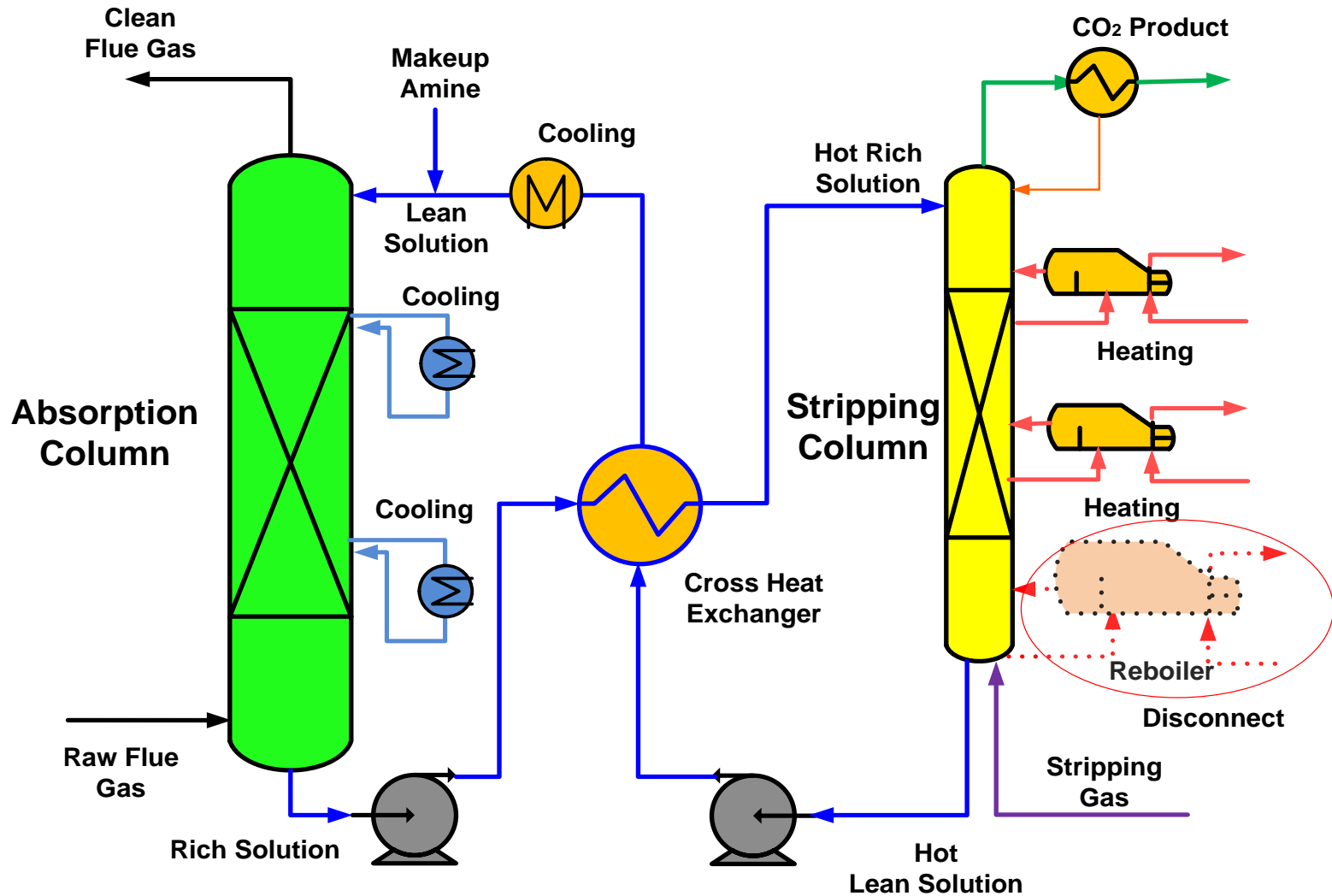

Optimized GPS Process

Task 4. Energy Performance of the Optimized GPS Process by Computer Simulation

Process	Baseline MEA	GPS with Refrigeration	Optimized GPS
Operating Pressure (atm)	1.8	~8	~8
Reaction Heat (kJ/kgCO ₂)	1870	1330	1330
Sensible Heat (kJ/kgCO ₂)	990	320	230
Stripping Heat (kJ/kgCO ₂)	690	140	140
Total Heat (kJ/kgCO ₂)	3550	1790	1700
Electricity Equivalent (kWh/kgCO ₂)	0.29	0.11	0.10
Other load (kWh/kgCO ₂)	0.04	0.04	0.04
Compression Work (kWh/kgCO ₂)	0.09	0.06	0.06
Electricity Equivalent (kWh/kgCO ₂)	0.42	0.21	0.20
Energy Penalty to SPC Plant (%)	30	18	17

Task 14. Revision of Techno-economic Analysis

Type of CO ₂ Capture Technology	Case 11	Case 12 MEA	GPS with Refrigeration	Final GPS
Power Production, MW				
Gross Power	580	663	762	773
Net Power	550	546	654	666
Capital Cost, \$MM				
Power Plant	866.4	1109.9	1123.7	1123.7
PCC Plant	0.0	410.8	447.5	410.8
CO ₂ Compression and Drying	0.0	46.4	75.8	55.0
Start Up Costs (2% TPC before Contingency)	15.5	26.4	27.7	27.6
Total Capital Cost, \$MM	881.9	1,593.5	1674.7	1,617.3
Operating Cost excl Fuel, \$MM/yr				
Fixed Operating Cost	13.8	20.5	22.9	20.5
Variable Operating Cost				
Non PCC related Opt Cost	20.0	33.6	35.6	33.6
NaOH		0.9	0.9	0.9
H ₂ SO ₄		0.3	0.3	0.3
Amine M/U		1.0	1.1	1.0
Active Carbon		0.6	0.5	0.6
Corrosion Inhibitor/Solvent MU		0.0	0.0	0.0
Total Operating Cost excl Fuel, \$MM/yr	33.8	56.9	61.3	56.9
Fuel Cost, \$MM/yr	64.5	92.0	92.0	92.0
LCOE (excl CO₂ TS&M), mills/kWh	63.9	112.0	97.6	92.5
% of Case 11 LCOE - Compare to 2007	100%	175%	153%	145%

Task 14. Revision of Techno-economic Analysis

	Base Case	GPS/Refrigeration	Optimized GPS
Total Output at Generator Terminals, kW	663,445	761,644	773,660
Auxiliary Load Summary, kW:			
Coal Handling and Conveying	490	490	490
Limestone Handling & Reagent Preparation	1,270	1,270	1,270
Pulverizers	3,990	3,990	3,990
Ash Handling	760	760	760
Primary Air Fans	1,870	1,870	1,870
Forced Draft Fans	2,380	2,380	2,380
Induced Draft Fans	10,120	10,120	10,120
SCR	70	70	70
Baghouse	100	100	100
FGD Pumps and Agitators	4,250	4,250	4,250
Misc Balance of Plant	2,000	2,000	2,000
Steam Turbine Auxiliaries	400	400	400
Condensate Pumps	630	630	630
Cooling Water Circulation Pumps **	12,260	15,476	15,476
Cooling Tower Fans	6,340	4,459	4,459
Transformer Losses	2,300	2,613	2,613
Amine CO₂ Capture Plant Auxiliaries	21,320	22,568	18
CO₂ Compression	46,900	34,100	38
Total Auxiliaries, kW	117,450	107,546	106,878
Net Power Export, kW	545,995	654,098	666,782
Net Plant Efficiency, % HHV	27.2	32.6	33.2
Net Plant Heat Rate, Btu/kW	12,536	10,464	10,275

Task 16: GPS Skid Design/ Fabrication and Testing

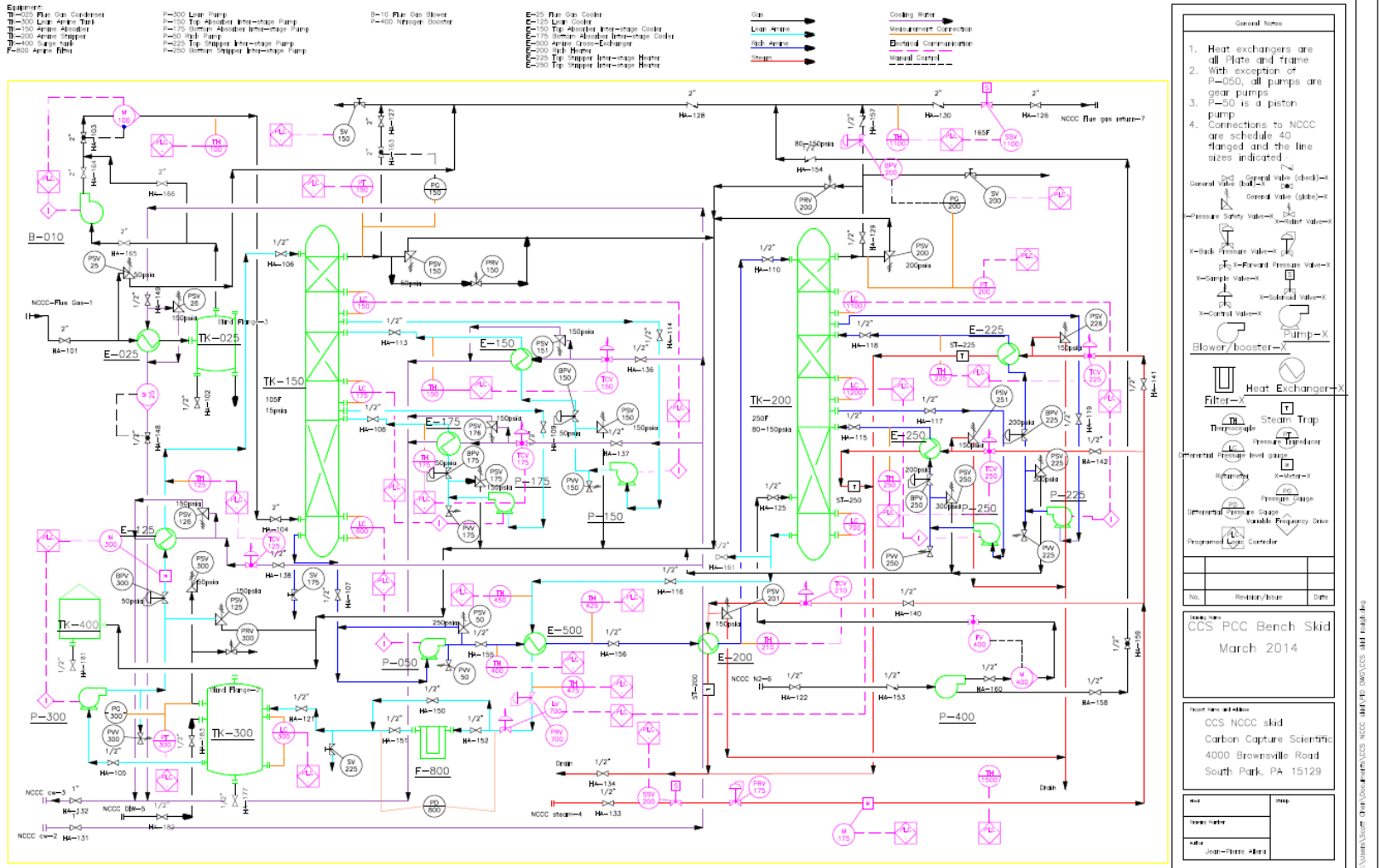

E:\Users\user\Drawings\CCS NCCC\01600_DWG\CCS 01600.rvt

Task 16: GPS Skid Design/ Fabrication and Testing

Columns

Absorber: ID=8", H=32'
Stripper: ID=6", H=30'



Task 16: GPS Skid Design/ Fabrication and Testing



Planned Tasks for BP3

Task	Title/Description	Focus	Organization	Duration
1	Project Planning & Management	Project management	CCS	7/1/14~6/30/15
12	Survey of EH&S of GPS process	EH&S survey	CCS	7/1/14~12/31/14
15.0	Updated techno-economic analysis		NEXANT	7/1/14~3/31/15
15.1	Equipment sizing using updated data	Economics	NEXANT	7/1/14~12/31/14
15.2	Techno-economic analysis	Economics	NEXANT	10/1/14~3/31/15
17.0	Task 17. Bench-Scale Testing of the Skid Mounted Column Based GPS System	Experiments to evaluate the GPS process	CCS	7/1/14~6/30/15
17.1	Bench unit commissioning	Process	CCS	7/1/14~7/31/14
17.2	Bench unit parametric testing	Process	CCS	8/1/14~9/30/14
17.3	Bench Unit long-term testing	Process and solvent	CCS	10/1/14~4/30/15
17.4	Equipment tear down and return to CCS facilities	Process	CCS	5/1/15~6/30/15

Proposed Milestones for BP3

Task	Title/Description	Planned Completion Date	Verification Method
12	Completion of Preliminary EH&S Assessment	12/30/2014	Topical Report
15	Completion of techno-economic analysis of the GPS system using updated data	3/31/2015	Topical Report
17	Complete commissioning of the skid-mounted GPS system at NCCC	7/30/2014	Review with NETL / NCCC
17	Completion of the parametric tests of GPS system at NCCC	9/30/2014	Review with NETL /NCCC
17	Completion of the continuous running of the GPS skid for >2000 hours	3/31/2015	Review with NETL / NCCC
17	Completion of equipment tear down and return to CCS facilities	6/30/2015	Review with NETL /NCCC

Success Criteria for BP3

Task	Description	Planned Completion Date	Actual Completion Date	Verification Method
15	Increase in capital equipment costs of less than or equal to 10% over existing process	3/31/2015		Topical Report and Review with NETL
17	Overall energy requirement of the GPS process less than electricity equivalent of 0.23kWh/kgCO ₂	9/30/2014		Review with NETL / NCCC
17	Cumulative running time of the GPS skid for >2000 hours	3/31/2015		Review with NETL / NCCC

Summary of Progress

- ❑ **Completed all major individual process unit tests at lab**
- ❑ **Key energy related milestones (simulation and experimental) achieved – demonstrates significant improvements over existing capture technologies**
- ❑ **Computer simulation task identified favorable process configuration which will reduce capital cost**
- ❑ **Rapid progress resulted in fabrication of a continuous skid-mounted GPS system to be tested at NCCC**